

S2 Series

Straight Side Mechanical Presses



165 . 220 . 330 . 440 . 660 . 880 . 1100 ton

Durable

Reliable

Versatile



STRAIGHT SIDE MECHANICAL PRESSES

Tough, durable Stamtec straight side presses deliver high performance for diversified stamping requirements in hand-fed, progressive and transfer die operations. Built to your exact specifications, or available in several standard models from 150 tons and up, Stamtec presses can also be integrated with automation to achieve the efficiency and productivity required to compete in today's demanding manufacturing environment.

Let Stamtec's experienced team help you make a wise decision in choosing the right stamping equipment for your operation!

Standard Features:

- ◆ **Eddy-current or Variable Frequency Drive:** either type is available per customer preference.
- ◆ **Hydraulic Overload Protection:** unique dual-valve system protects both sides of the press from overload conditions.
- ◆ **Air Clutch and Brake:** either separated or combination type based on the specific application and press construction.
- ◆ **Micro-processor-based press control system:** user-friendly functionality, and compliance with global or local requirements for safety and operability.

Optional Features & Accessories:

- ◆ **Customized press and automation/ monitoring controls:** using well-known brands such as Mitsubishi, Siemens, Allen Bradley, Wintriss, Link, etc.
- ◆ **Custom Specifications:** (e.g. bed size, stroke length, die height, etc.)
- ◆ **Link Motion:** Helps produce better-formed parts at higher production rates.
- ◆ **Hydraulic Clutch, or Wet Clutch:** based on application requirements and customer preference.
- ◆ **Quick Die Change Systems:** Hydraulic die clamps, lifters, rollers, and bolster extensions.
- ◆ **Rolling Bolsters:** Assist handling, loading, and transporting of large or difficult to handle dies
- ◆ **Die Cushions:** Based on customer's application requirements.

Robust Drive Train Systems:

The gears on Stamtec presses are hardened and precision ground for quiet, vibration-free performance and long life. Pinions are typically machined to alloy shaft forgings to eliminate the keyed joint which requires a larger than otherwise necessary shaft diameter. Crankshafts are machined and precision ground from high carbon steel forgings, and normalized to eliminate harmful stress concentrations. Main and crankshaft bearing surfaces are manufactured from alloys chosen based on the specific application. Flywheel, driveshaft and intermediate shafts run in anti friction or spherical roller bearings. All materials are selected to provide superior strength, performance, and wear resistance characteristics.

Drive Arrangements to Meet Diversified Stamping Needs

Stamtec presses employ a variety of drive arrangements depending on application requirements including type of work (blanking, drawing, forming), type and size of dies, parts material specifications, production volumes required, etc.

Single-Geared, Opposed, Counter-Rotating, Crankshafts

This arrangement is suitable for smaller tonnage presses with slide areas that are relatively long L-R vs. F-B, and capacities typically not exceeding 400 tons.



Single-Geared or Double Geared, Single-End Drive

This arrangement is suitable for blanking, forming and medium depth drawing on to presses with relatively small L-R dimensions of slide, typically lower than 300 tons capacity.

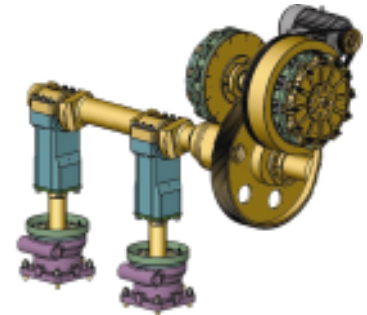

Single-Geared or Doubled-Geared, Center Drive

This arrangement is suitable for heavy blanking, forming and medium depth drawing at higher speeds on presses with larger L to R dimensions of slide. Press tonnage would usually be from 200 tons up to 600 tons.



Single-Geared or Double Geared, Twin-End Drive

This arrangement may be necessary for heavier duty stamping on presses when larger L to R dimension of slide, longer strokes, and higher tonnage rating points. These types of drive systems run at the slower speeds often required for are required complex forming and drawing operations. Press capacity can be up to 1000 tons.



Rigid, Box Section, All-Steel Frames:

Stamtec rugged press frames are rigid, box type fabricated steel structures put through rigorous FEA (Finite Element Analysis) prior to manufacturing, and are designed for exceptional strength to properly resist deflection, torsion and vibration. This rigidity assures continued alignment of components even under heavy load, provides greater stamping accuracy, and helps extend die life. When required or specified, tie rod construction is employed to permit disassembly and reassembly. In smaller presses the frame components are welded together instead of tie-rod constructed, to form a single-piece unitized frame. Large window openings are provided to permit coil or transfer feeding across most or all of front to back dimension of the bed. The massive bed is built to a standard of no more than .0015" deflection per foot of bed length left to right and front to back, with a full-capacity load symmetrically distributed over 2/3 of the bed area. By providing superior compressive strength, and maximum resistance to deflection, torsion, and vibration, the Stamtec's press frame helps you produce precision stampings with minimum die wear.

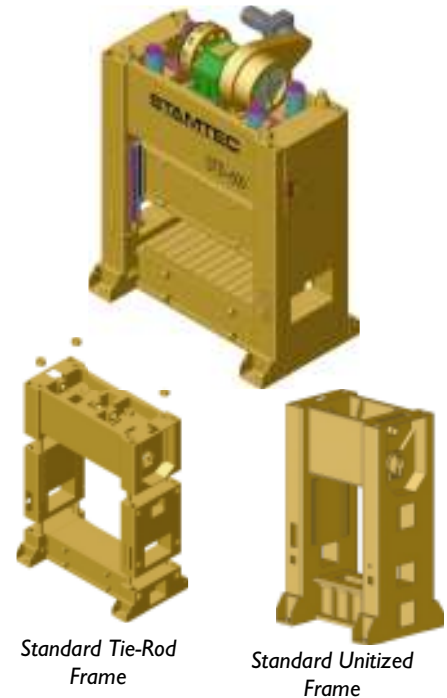

Box-Type Slide:

The Stamtec slide is a rigid, box type structure, fully thermal stress relieved, and built to a standard of no more than .0015" deflection per foot with the load symmetrically distributed over 2/3 of the slide area. It is guided by exceptionally long eight point gibbing for maximum control and accuracy. The adjustable gib-liners are of a nickel bronze alloy, ground for smooth finish and accurate fit. The ways are finished ground or machined for precision alignment to insure greater parts accuracy and longer die life. The slide is counterbalanced by one or two air cylinders, as required by the slide size. These are adjustable, air pressure cylinders, and can be set to properly compensate for the weight of the upper die. Stamtec's slide design and construction provides maximum strength to resist deflection and torsion.

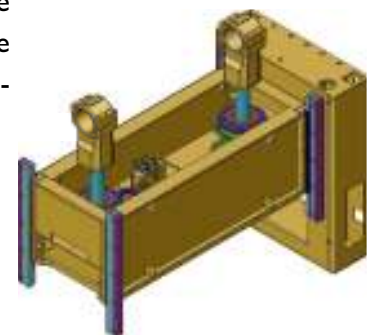

Eight Point Four Way Gibs

Stamtec's precise 8-point gibbing provides for accurate guiding of the slide throughout the stroke. Extra long gibs keep the slide fully contained at all points of stroke and slide adjustment. This feature, in conjunction with the rigid box type slide, results in maintenance of parallelism to the bed. Simple gib adjustment mechanisms allow for quick and easy alignment and setting of clearances.

Clutch and Brake:

Many clutch and brake options are available, and are selected based on the application and budget:

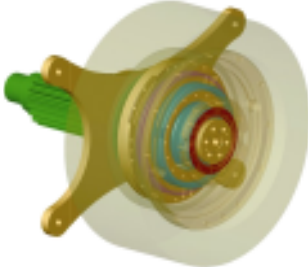

- ◆ independent air friction clutch and brake
- ◆ combination air friction clutch and brake
- ◆ hydraulic clutch and brake
- ◆ wet clutch and brake

All units are designed to operate in a fail-safe mode. Should either electric or air supply fail, the clutch will disengage and the brake will engage.

Main Motor and Drives:

Stamtec straight side presses are equipped with a compact eddy current variable speed drive or A/C variable frequency drive to permit adjusting the press speed infinitely within its range for optimum tuning of the die, material, feed length, automation, and parts removal.

Hydraulic Overload System:

Highly responsive with an immediate oil dump feature and a unique dual-valve pressure switch arrangement, Stamtec fast-acting H.O.L.P. relieves the pressure of a tonnage overload in milliseconds, and helps protect both press and tooling. If an overload occurs, even on just one side of the press, oil pressure in the cylinder is released and simultaneously, the press stops. This reliable system can be quickly and easily reset by inching the slide back to top dead center, which automatically reactivates the pump, builds up the hydraulic pressure to the pre-overload setting, and resets the press control to allow resumption of normal operation.



Circulating Oil Lubrication System:

A motorized, forced circulation lubrication system supplies all rotary or sliding friction surfaces and anti-friction bearings with a controlled flow of filtered oil. Drive gears are lubricated by an enclosed oil bath and spray system. The press is protected against lubrication malfunctions by a pressure sensing system.

S m a r t
Micro-Processor Press Control System

MPC-3000 Series

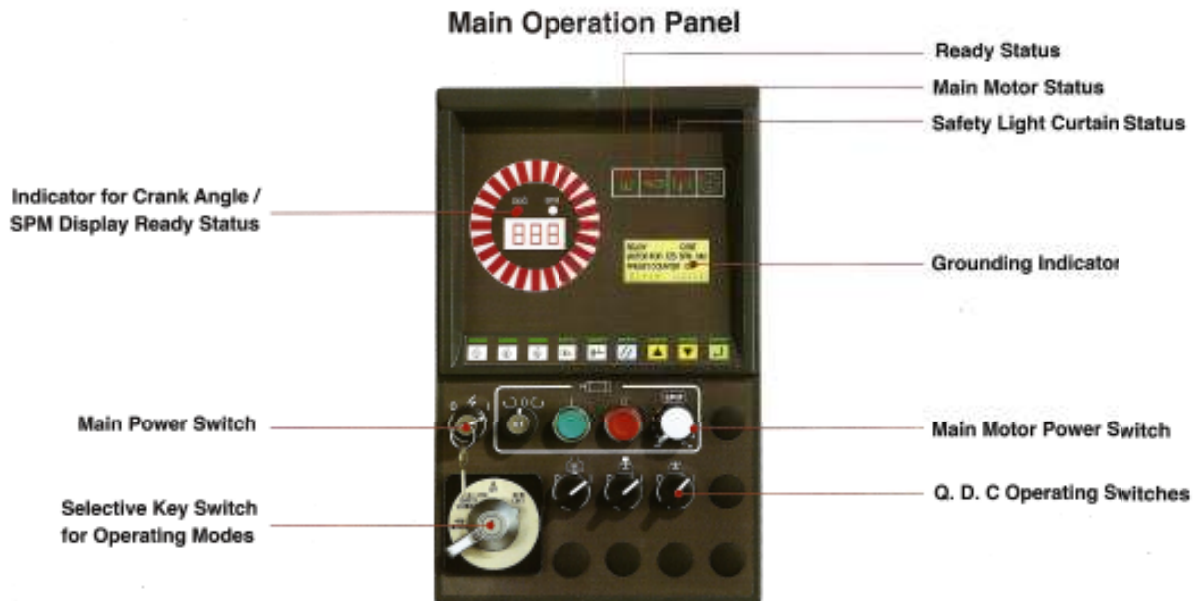

Press Controls:

I. Operation Status Monitoring

1. Motion detector monitors broken crankshaft, excessive wear of lining and engagement of clutch and brake device.
2. LCD screen displays motor status (Forward/Reverse/ Amperage/SPM) with set function.
3. Dual-circuit protection for safety light curtain and overrun.
4. Panel-displayed operation modes are error messages with Trouble-shooting instruction.

II. Electronic Angle Control

1. Cam On/OFF angle can be set from LCD displaying screen.
2. Standard 6 spare cams are reserved. Optional 16 spare cams can be added without mechanical modifications.
3. Brake Monitor is equipped with automatic slip-angle correction within a limited range against inaccurate TDC stop position caused by lining wear and change of slide speed.

III. Counters

1. Total counter pre-set counter, chop counter, maintenance counter, and life Counter are standard features with the system.
2. Setting figures and Status of counters are displayed from LVD Displaying Screen.

IV. Provision of Interface for Peripheral Equipment

1. Cam angle controlled misfeed detection circuits A1 & B1 can be set for ON/OFF, and A2 & B2 can be set for all-time detection. A and B port can be set individually.
2. RS-485 module is available for remote communication monitoring and controlling.

In addition to our standard MPC Series controls, our worldwide experience allows us to build custom controls to meet your needs, using well-known brands such as Allen Bradley, Honeywell Wintriss, Link, Siemens, Mitsubishi, etc.

S2 SPECIFICATIONS:

		S2-165	S2-220	S2-330	S2-330 ProgMax	S2-440	S2-440 ProgMax	S2-660	S2-660 Progmax	S2-880 Progmax	S2-1100 Progmax
Capacity	US Tons	165	220	330	330	440	440	660	660	880	1110
	Metric Tons	150	200	300	300	400	400	600	660	800	1000
Speed	spm	60~120	50 ~ 120	30-60	30 ~ 70	20 ~ 50	25 ~ 70	20 ~ 40	25 ~ 60	20-50	20-50
Rated Tonnage Point ABDC	in.	0.236	0.236	0.354	0.275	0.512	0.275	0.512	0.275	0.354	0.354
	mm	6	6	9	7	13	7	13	7	9	9
Stroke Length	in.	5.91	6.3	10.03	10.03	12.2	10.03	14	12	15.9	15.9
	mm	150	160	254	254	310	254	355	305	404	404
Die Height, Bolster to Slide (SDAU)	in.	15.75	19.7	30.12	26	30.12	30.12	34	30.12	30.12	30.12
	mm	400	500	765	660	765	765	863	765	765	765
Slide Adjustment	in.	5.91	6.3	8.27	8.27	9.84	9.84	10.03	10.03	10.03	10.03
	mm	150	160	210	210	250	250	255	255	255	255
Slide Area (L-R x F-B)	in.	60 x 42	72 x 48	84 x 48	84 x 50	98 x 55	98 x 55	108 x 60	108 x 55	120 x 60	144 x 60
	mm	1524 x 1066	1828 x 1219	2489 x 1397	2438 x 1270	3048 x 1524	3048 x 1397	3657 x 1524	3657 x 1397	3657 x 1524	3657 x 1524
	in.	72 x 42	84 x 48	98 x 55	96 x 50	120 x 60	120 x 55	120 x 60	120 x 55	144 x 60	168 x 60
	mm	1828 x 1066	2133 x 1219	3048 x 1397	2438 x 1270	3048 x 1524	3048 x 1397	3048 x 1524	3048 x 1397	3657 x 1524	4267 x 1524
	in.	84 x 48	98 x 55	110 x 55	110 x 55	144 x 60	144 x 55	144 x 60	144 x 55	168 x 60	186 x 72
	mm	2133 x 1219	3048 x 1397	2794 x 1397	2794 x 1397	3657 x 1524	3657 x 1397	3657 x 1524	3657 x 1397	4267 x 1524	4724 x 1828
	in.	N/A	N/A	122 x 55	156 x 60	156 x 60	156 x 60	168 x 60	168 x 55	186 x 72	204 x 72
	mm	N/A	N/A	3098 x 1397	3962 x 1524	3962 x 1524	3962 x 1524	4267 x 1524	4267 x 1397	4724 x 1828	5181 x 1828
Bolster Area (L-R x F-B)	in.	60 x 42	72 x 48	98 x 55	96 x 50	120 x 60	120 x 55	144 x 60	144 x 55	144 x 60	144 x 60
	mm	1524 x 1066	1828 x 1219	2489 x 1397	2438 x 1270	3048 x 1524	3048 x 1397	3657 x 1524	3657 x 1397	3657 x 1524	3657 x 1524
	in.	72 x 42	84 x 48	98 x 55	96 x 50	120 x 60	120 x 55	120 x 60	120 x 55	144 x 60	168 x 60
	mm	1828 x 1066	2133 x 1219	3048 x 1397	2438 x 1270	3048 x 1524	3048 x 1397	3048 x 1524	3048 x 1397	3657 x 1524	4267 x 1524
	in.	84 x 48	98 x 55	110 x 55	110 x 55	144 x 60	144 x 55	144 x 60	144 x 55	168 x 60	186 x 72
	mm	2133 x 1219	3048 x 1397	2794 x 1397	2794 x 1397	3657 x 1524	3657 x 1397	3657 x 1524	3657 x 1397	4267 x 1524	4724 x 1828
	in.	N/A	N/A	122 x 55	156 x 60	156 x 60	156 x 60	168 x 60	168 x 55	186 x 72	204 x 72
	mm	N/A	N/A	3098 x 1397	3962 x 1524	3962 x 1524	3962 x 1524	4267 x 1524	4267 x 1397	4724 x 1828	5181 x 1828
Bolster Thickness	in.	5.91	6.3	7.08	7.08	7.87	7.08	9.4	7.87	10.6	12
	mm	150	160	180	180	200	180	239	200	270	305
Working Height- Floor to Top of Bolster	in.	37	39.37	39.37	39.37	48	51.92	59.25	58	47 (press in pit)	47 (press in pit)
	mm	940	1000	1000	1000	1219	1319	1504	1473	1194 (press in pit)	1194 (press in pit)
Opening in Side Frames (F-B x H)	in.	25.00 x 17.70	31.50 x 19.70	35.43 x 27.56	35.00 x 28.00	47.24 x 31.50	47.24 x 31.50	53.94 x 31.50	44.09 x 31.50	44.09 x 31.50	44.09 x 31.50
	mm	635 x 450	800 x 500	900 x 700	889 x 711	1200 x 800	1200 x 800	1370 x 800	1120 x 800	1120 x 800	1120 x 800

Parallelism: Slide to Bolster - .001" per foot or less

Deflection:.0015" per foot or less R to L & F to B with 2/3 of the bed area symmetrically loaded.

For custom features and specifications please consult Stamtec.

STAMTEC®

MECHANICAL PRESSES

Stamtec's 72,000 sq. ft. Sales, Service, Engineering and Manufacturing facility is located in Manchester, TN, near Nashville. The facility is the Stamtec distribution, service and manufacturing headquarters for the North American market, including Canada, Mexico, and the United States.



Stamtec is a subsidiary of Chin Fong Group, Taiwan, R.O.C.



Large In-Stock Inventory!



Service Trucks and Warehouse,
Manchester, TN.

STAMTEC®

MECHANICAL PRESSES

4160 Hillsboro Highway Manchester, TN 37355

Phone: 931-393-5050 Fax: 931-393-5060

E-mail: sales@stamtec.com



The contents disclosed in this catalog, including pictures, data, wording & drawings, are exclusive property of Stamtec, Inc. Unauthorized duplication or use part or whole of this catalog is prohibited. Stamtec reserves rights to modify the specifications & features, due to product improvements, without further notification. Optional accessories showing on this picture are for reference only.